

PERFORMANCE PARAMETERS

1. Recommended inlet water temperature: 60°F
2. Maximum Operating Temperature: 200°F
3. Maximum Operating Pressure: 150 PSI

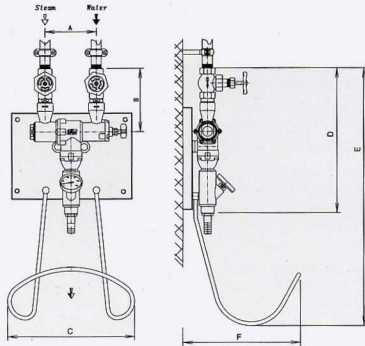

MODEL	A	B	C	D	E	F	WEIGHT
4000	5.50"	7.00"	9.00"	15.50"	26.00"	10.00"	20 lbs

Performance Curves

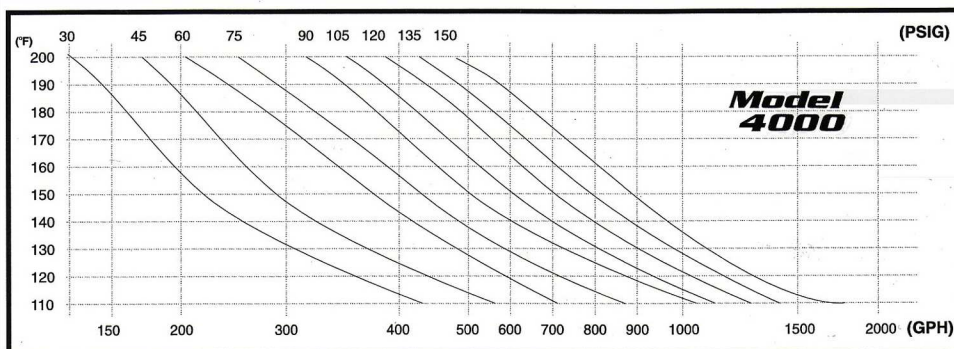

Installation Recommendations

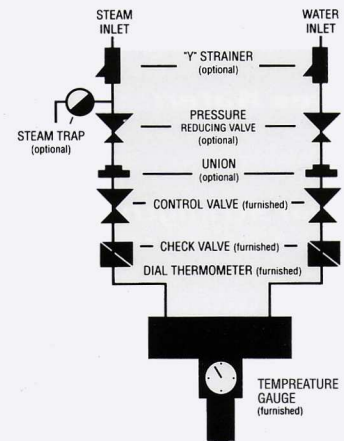

1. If overheating occurs due to system malfunctions, (i.e. restrictions in pipelines, etc...) immediately turn down steam valve. If overheating occurs due to uncontrollable pressure fluctuations, a pressure regulator will be required.
2. Limitations in use: Not for use with superheated steam.

Pressure Requirements & Testing

The Steamaster 4000 series operates on half the steam pressure required for competitive units and every unit is performance tested prior to shipment.

Model 4000	STEAM		WATER PRESSURE	
	MINIMUM	MAXIMUM	MINIMUM	MAXIMUM
	40 PSI	125 PSI	50 PSI	80 PSI

Technical Services

Full technical advice and information is available by calling our number:

OHIOCRAFT INDUSTRIAL PRODUCTS
(937) 558-2497